

GAU212P-15255 Universal Gate Drive Prototype Board

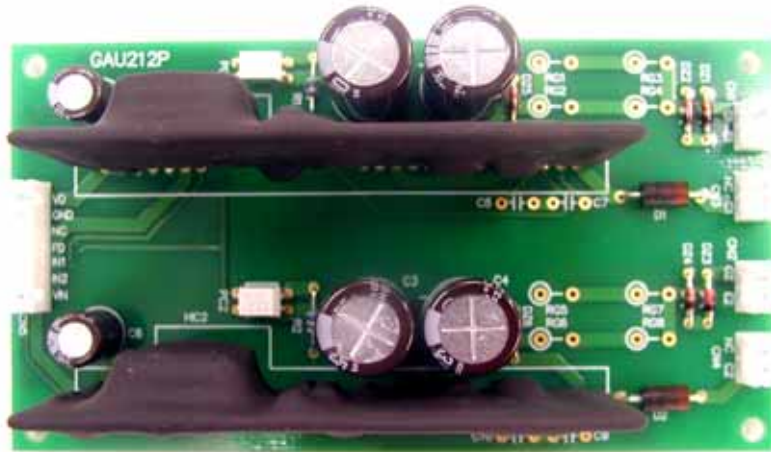

Size : 65 x 120 x 40t

Gate Driver : VLA500-01R

FEATURE

- >Built in the isolated DC-DC converter for gate drive
- >Output peak current is +/-12A(max)
- >Built in short circuit protection
- >Electrical isolation voltage is 2500Vrms (for 1 minute)
- >Two way power supply system for drivers and input signal (VD=15V , VIN=5V)
- >CMOS compatible input interface

RECOMMENDED IGBT MODULES

- MITSUBISHI H, NF series IGBT modules
- VCES = 600V series ~ 600A class
- VCES = 1200V series ~ 1400A class

BLOCK DIAGRAM

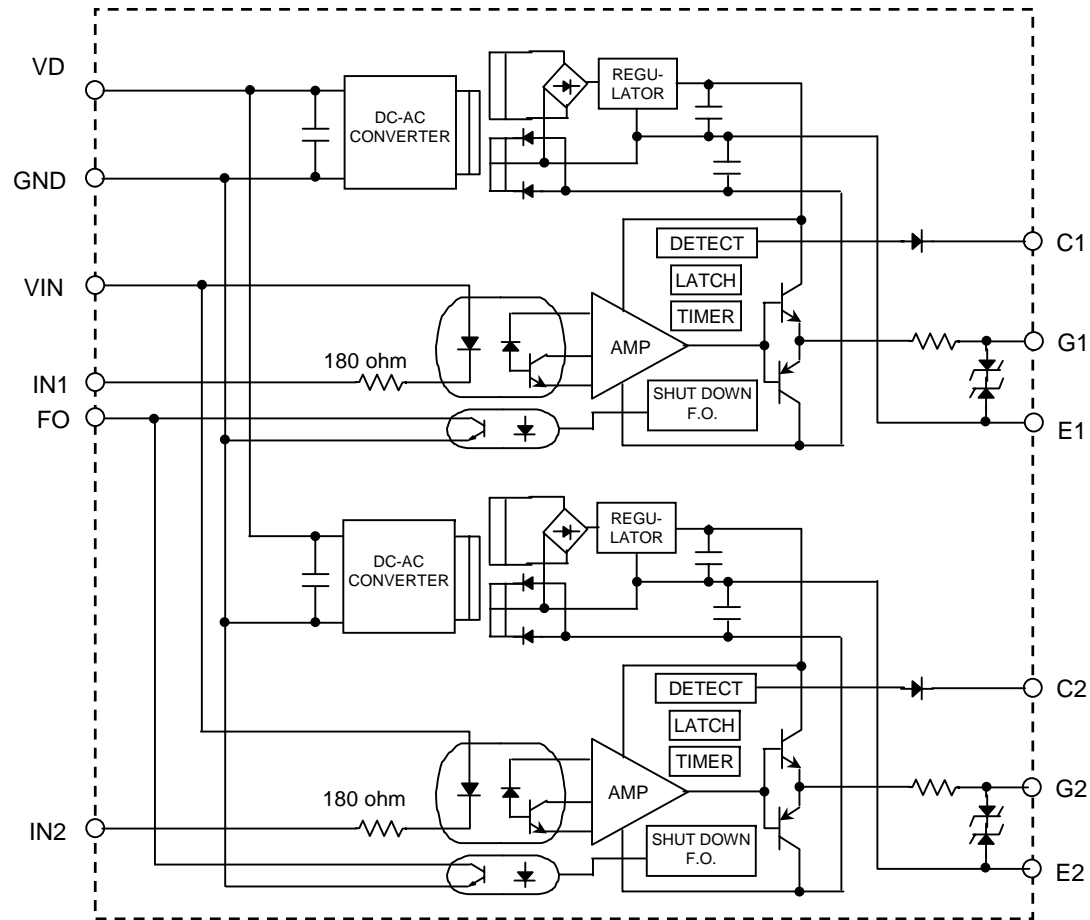

MAXIMUM RATINGS (unless otherwise noted, Ta=25C)

Symbol	Parameter	Conditions	Ratings	Unit
VD	Supply voltage	DC	16.5	V
VI	Input signal voltage	Applied between VIN – IN1,2 50% Duty cycle , pulse width 1ms	-1 ~ +7	V
IOHP	Output peak current	Pulse width 2us	-12	A
IOLP			12	A
Viso	Isolation voltage	Sine wave voltage 60Hz, for 1min	2500	Vrms
Topr	Operating temperature	No condensation allowable	-20 ~ 60	deg
Tstg	Storage temperature	No condensation allowable	-25 ~ 85	deg
Idrive	Gate drive current	Gate average current (Per one circuit)	210	mA

ELECTRICAL CHARACTERISTICS (unless otherwise noted, Ta=25C, VD=15V)

Symbol	Parameter	Conditions	Limits			Unit
			Min	Typ	Max	
VD	Supply voltage	Recommended range	14.2	15	15.8	V
VIN	Pull-up voltage on input side	Recommended range	4.75	5	5.25	V
I _{IH}	"H" input signal current	Recommended range	15.2	16	19	mA
f	Switching frequency	Recommended range	-	-	20	kHz
R _G	Gate resistance	Recommended range	1	-	-	ohm
V _{OH}	Plus bias voltage	-	14	15.5	16.5	V
V _{OL}	Minus bias voltage	-	-5.5	-8	-11	V
t _{PLH}	"L-H" propagation time	I _{IH} = 16mA	-	0.6	1	us
t _{PHL}	"H-L" propagation time	I _{IH} = 16mA	-	1	1.3	us
V _{SC}	SC detect voltage	-	15	-	-	V

INNER CIRCUIT

HIC1,2	VLA500-01R	ISAHAYA
PC1,2	TLP421	TOSHIBA
D1,2	RP1H	SanKen
DZ1,2,3,4	Vz=18V,500mW	
DZ5,6	Vz=30V,500mW	
C1,2,3,4	1000uF,35V	Low impedance
C5,6	100uF,50V	Low impedance
RG	Gate Resistor	
R1,2	4.7kohm,250mW	
CN1,2,3,4	B2B-XH-A	JST
CN5	B7B-XH-A	JST

*1) Gate Resistor is not installed at the time of shipment.
Please solder the chosen resistor.

*2) C7,8,9,10 is not installed at the time of shipment.
Please solder the chosen condenser if needed.
(50V,ceramic)

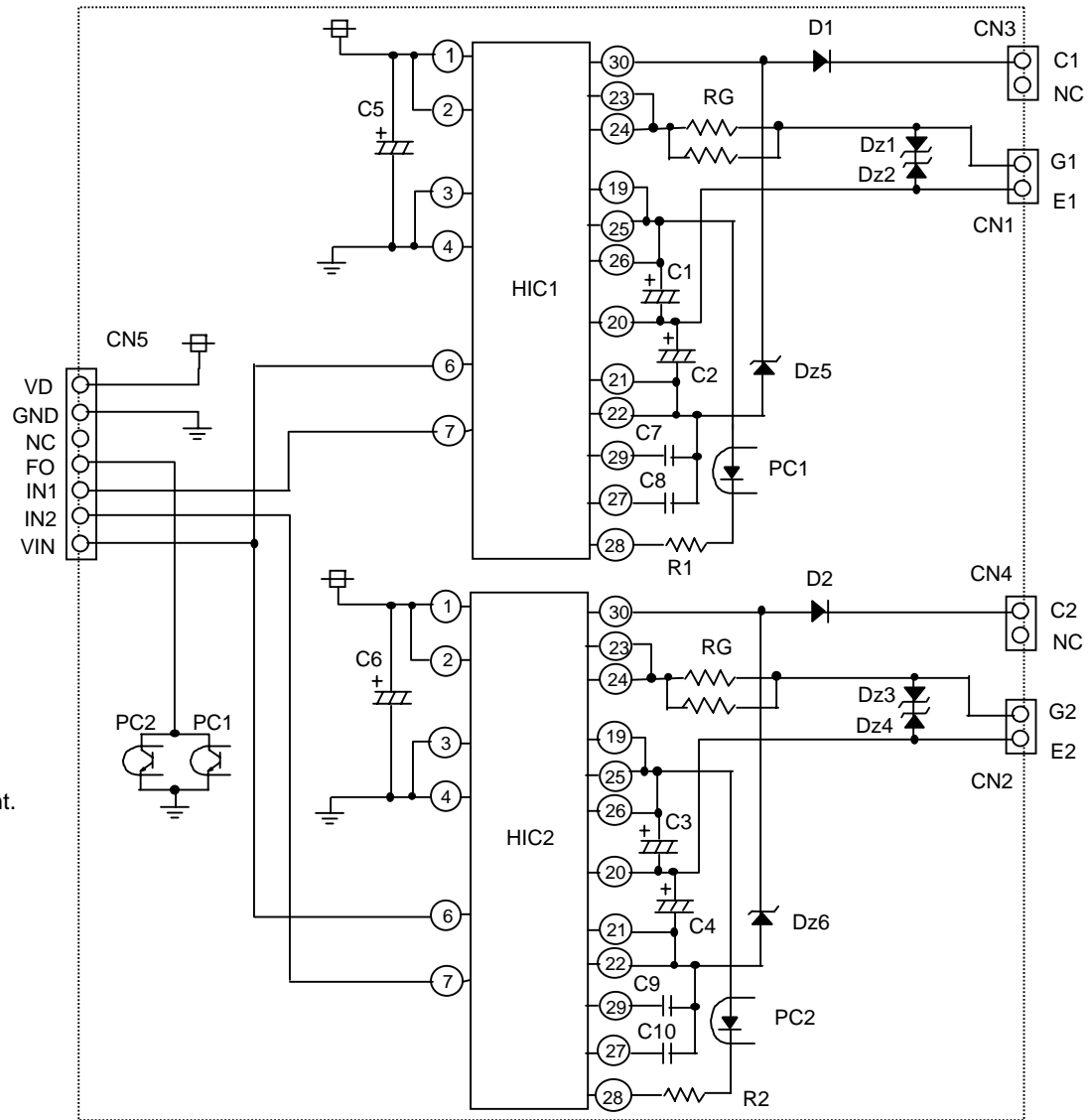

APPLICATION EXAMPLE

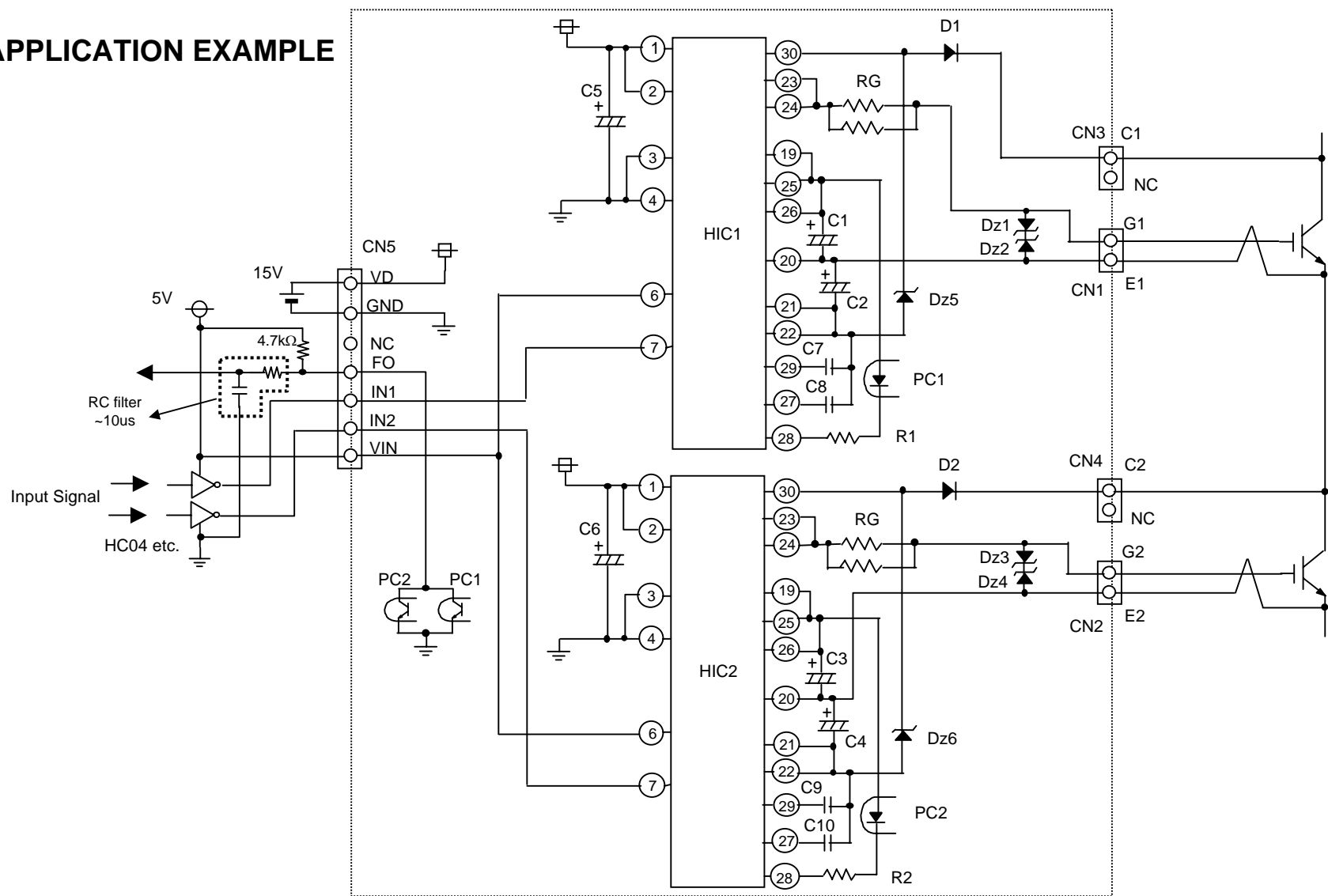

Part arrangement & Size

