

**POW-R-BLOK™**  
**Dual SCR/Diode Isolated Module**  
**150 Amperes / 2000 to 2500 Volts**

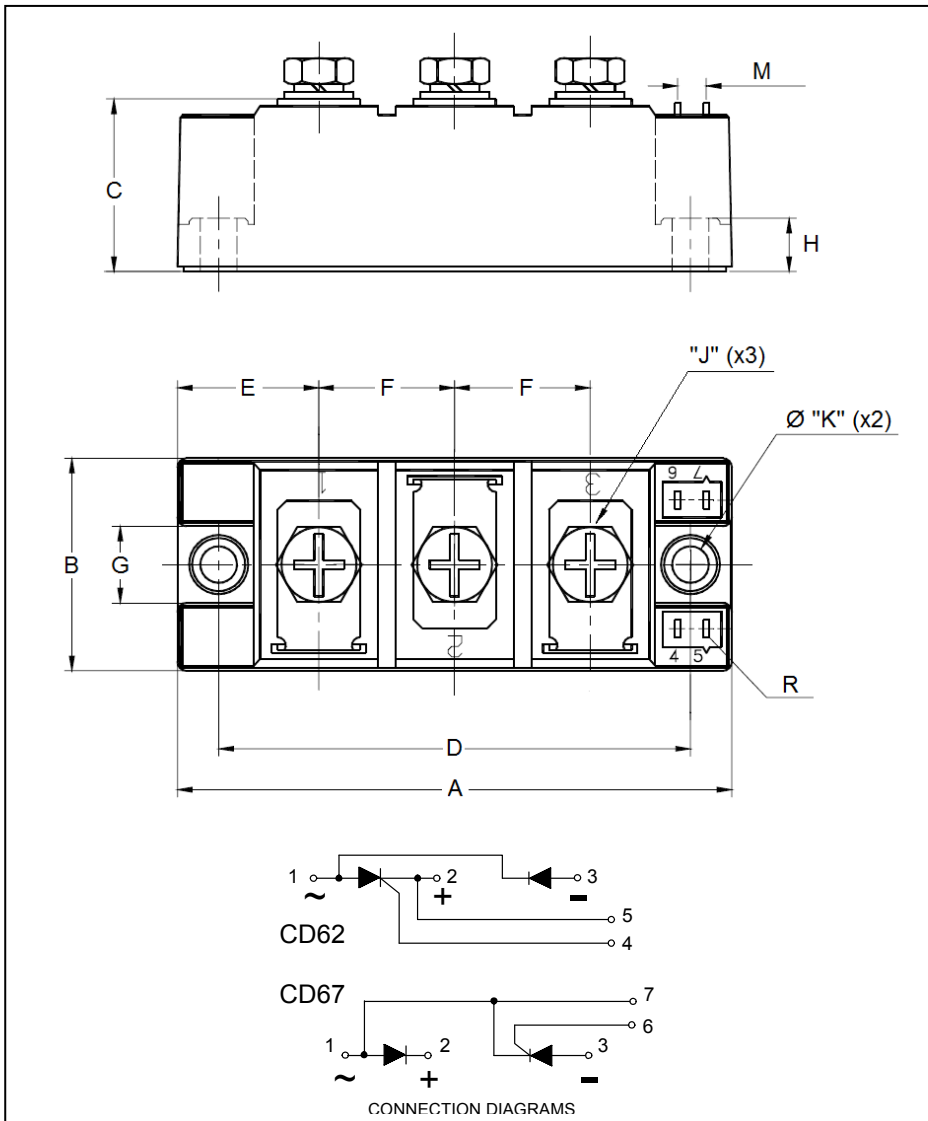

**Description:**

Powerex SCR/Diode Modules are designed for use in applications requiring phase control and isolated packaging. The modules are isolated for easy mounting with other components on a common heatsink.

**Features:**

- Electrically Isolated Heatsinking
- Compression bonded construction
- Low Thermal Impedance for Improved Current Capability
- Quick Connect Gate Terminal with Provision for Keyed Mating Plug

**Benefits:**

- No Additional Insulation Components Required
- Easy Installation
- No Clamping Components Required
- Reduce Engineering Time

**Applications:**

- Bridge Circuits
- AC & DC Motor Drives
- Battery Supplies
- Power Supplies
- Large IGBT Circuit Front Ends
- Lighting Control
- Heat & Temperature Control
- Welders

**Outline Dimensions**

Dimension	Inches	Millimeters
A	3.70	94
B	1.34	34
C	1.15	29.2
D	3.15	80
E	0.94	24
F	0.91	23
G	0.51	13
H	0.35	9
J	M6	M6
K	0.24	6.2
M	0.19	4.9
R	0.03 X 0.11	2.8 X 0.8

Note: Dimensions are for reference only.

**Ordering Information:**

Select the complete nine digit module part number from the table below. Example: CD622215C is a 2200Volt, 150 Ampere SCR/ Diode Isolated POW-R-BLOK™ Module

Type	Voltage Volts (x100)	Current Amperes	Version
CD62	20	15	C
CD67	22	(150 A)	
	24		
	25		



**CD62\_\_15C**  
**CD67\_\_15C**

Powerex, Inc., 173 Pavilion Lane, Youngwood, Pennsylvania 15697 (724) 925-7272  
<http://www.pwr.com>

**POW-R-BLOK™**  
**Dual SCR/Diode Isolated Module**  
**150 Amperes / 2000 to 2500 Volts**

**Absolute Maximum Ratings**

Characteristics	Conditions	Symbol		Units
Repetitive Peak Forward and Reverse Blocking Voltage		$V_{DRM}$ & $V_{RRM}$	2000 to 2500	V
Non-Repetitive Peak Reverse Blocking Voltage (t < 5 msec)		$V_{RSM}$	$V_{RRM} + 200$	V
RMS Forward Current	180° Conduction, $T_C=83^\circ\text{C}$	$I_{T(RMS)}$	235	A
Average Forward Current	180° Conduction, $T_C=83^\circ\text{C}$	$I_{T(AV)}$	150	A
Peak One Cycle Surge Current, Non-Repetitive	50 Hz, 60% $V_{RRM}$ reapplied, $T_j=125^\circ\text{C}$	$I_{TSM}$	4,500	A
$I^2t$ for Fusing for One Cycle	50 Hz, 60% $V_{RRM}$ reapplied, $T_j=125^\circ\text{C}$	$I^2t$	103,000	$\text{A}^2 \text{sec}$
Maximum Rate-of-Rise of On-State Current, Repetitive	$T_j=125^\circ\text{C}$ , $I_{TM}=320\text{A}$ , $I_G=1.5\text{A}$ , $T_r < 0.5\mu\text{s}$	di/dt	100	$\text{A}/\mu\text{s}$
Operating Temperature		$T_J$	-40 to +125	$^\circ\text{C}$
Storage Temperature		$T_{stg}$	-40 to +125	$^\circ\text{C}$
Max. Mounting Torque, M6 Mounting Screw on Terminals			53 6	in.-Lb. Nm
Max. Mounting Torque, Module to Heatsink			53 6	in.-Lb. Nm
Module Weight, Typical			320 0.71	g lb
V Isolation @ 25C	$T_j= 25^\circ\text{C}$ , 1 minute	$V_{rms}$	2500	V
	$T_j= 25^\circ\text{C}$ , 1 second	$V_{rms}$	3000	V

Information presented is based upon manufacturers testing and projected capabilities.  
 This information is subject to change without notice.  
 The manufacturer makes no claim as to the suitability of use, reliability, capability,  
 or future availability of this product.

**Electrical Characteristics, T<sub>J</sub>=25°C unless otherwise specified**

Characteristics	Symbol	Test Conditions	Min.	Max.	Units
Repetitive Peak Forward Leakage Current	I <sub>DRM</sub>	At V <sub>DRM</sub> , T <sub>J</sub> =125°C		25	mA
Repetitive Peak Reverse Leakage Current	I <sub>RDM</sub>	At V <sub>RDM</sub> , T <sub>J</sub> =125°C		25	mA
Peak On-State Voltage	V <sub>TM</sub> / V <sub>FM</sub>	I <sub>TM</sub> / I <sub>FM</sub> = 480A		2.20	V
Threshold Voltage, Low-level	V <sub>(TO)1</sub>	T <sub>J</sub> = 125°C, I = 16.7% x πI <sub>T(AV)</sub> to πI <sub>T(AV)</sub>		1.10	V
Slope Resistance, Low-level	r <sub>T1</sub>			1.96	mΩ
Minimum dV/dt	dV/dt	Exponential to 2/3 V <sub>DRM</sub> T <sub>J</sub> =125°C, Gate Open	800		V/μs
Gate Trigger Current	I <sub>GT</sub>	T <sub>J</sub> = 25°C, V <sub>D</sub> =12V, I <sub>A</sub> = 1A		150	mA
Gate Trigger Voltage	V <sub>GT</sub>	T <sub>J</sub> = 25°C, V <sub>D</sub> =12V, I <sub>A</sub> = 1A		3.0	Volts
Non-Triggering Gate Voltage	V <sub>GDM</sub>	T <sub>J</sub> =125°C, V <sub>D</sub> =V <sub>DRM</sub>		1.0	Volts
Non-Triggering Gate Current	I <sub>GDM</sub>	T <sub>J</sub> =125°C, V <sub>D</sub> =V <sub>DRM</sub>		30	mA
Holding Current	I <sub>H</sub>	T <sub>J</sub> =25°C	150	(Typical)	mA

**Thermal Characteristics**

Characteristics	Symbol		Max.	Units
Thermal Resistance, Junction to Case DC Operation	R <sub>ΘJ-C</sub>	Per Junction, both conducting	0.17	°C/W
Thermal Resistance, Case to Sink Lubricated	R <sub>ΘC-S</sub>	Per Module	0.08	°C/W

Powerex, Inc., 173 Pavilion Lane, Youngwood, Pennsylvania 15697 (724) 925-7272  
http://www.pwr.com

### POW-R-BLOK<sup>™</sup> Dual SCR/Diode Isolated Module 150 Amperes / 2000 to 2500 Volts

Maximum On-State Forward Voltage Drop  
(T<sub>j</sub> = 125 °C)

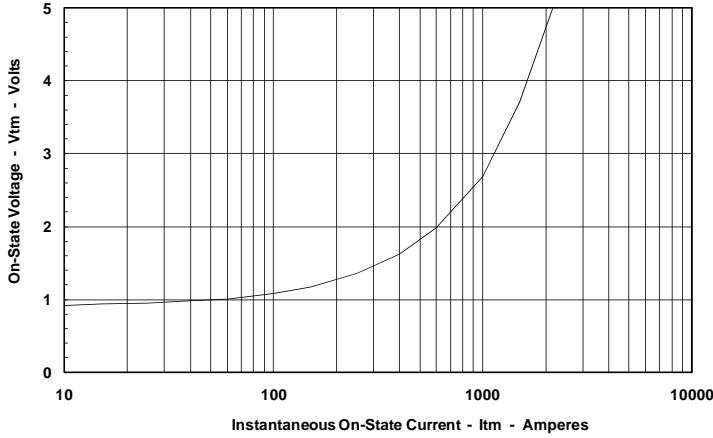

Maximum Transient Thermal Impedance  
(Junction to Case)

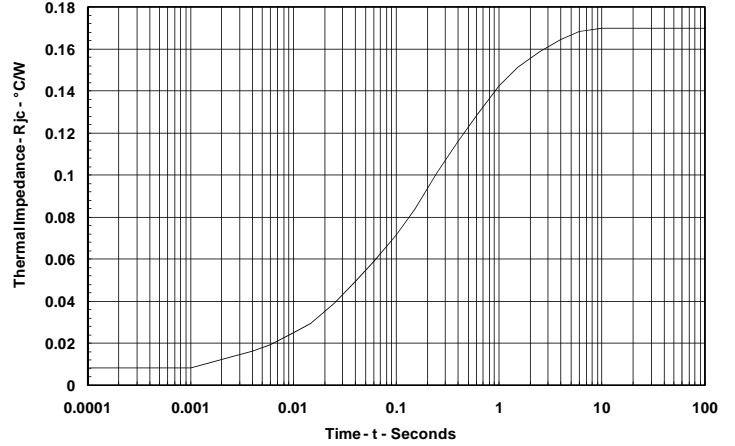

Maximum On-State Power Dissipation  
(Sinusoidal Waveform)

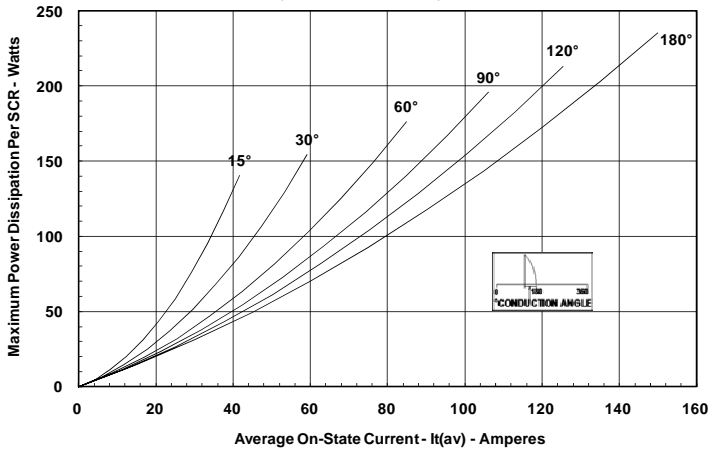

Maximum Allowable Case Temperature  
(Sinusoidal Waveform)

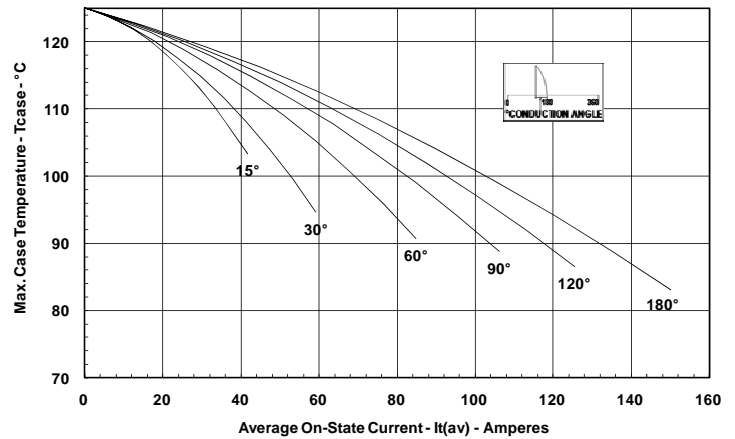

Maximum On-State Power Dissipation  
(Rectangular Waveform)

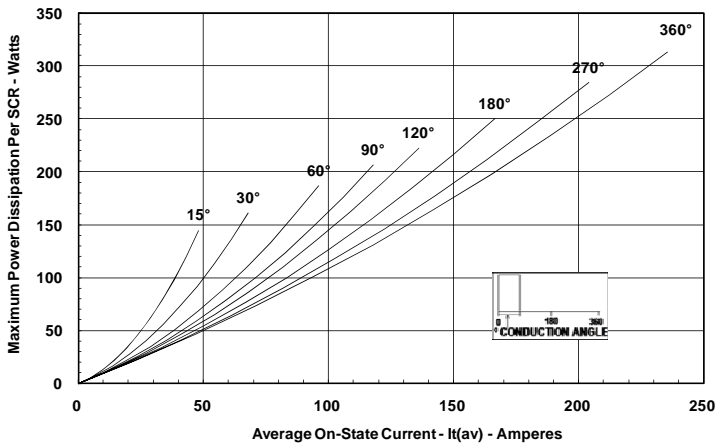

Maximum Allowable Case Temperature  
(Rectangular Waveform)

